

T-46-13-47

EP600

ALTERA

16-MACROCELL EPLD

EP600

FEATURES

- High density logic replacement for TTL and 74HC.
- Functional and pin compatible with the Altera EP600.
- High speed, tpd = 45 ns.
- Asynchronous clocking of all registers or banked register operation from 2 synchronous clocks.
- 16 Macrocells with configurable I/O architecture allowing 20 inputs and 16 outputs.
- "Zero Power" (typically 20µA standby).
- Programmable registers providing D,T,SR or JK flipflops with individual Asynchronous Clear control.
- 100% generically testable-provides 100% programming yield.
- Programmable "Security Bit" allows total protection of proprietary designs.
- Package options include both a 24 pin, 300 mil DIP and a 28 pin J-leaded chip carrier.
- Full software support featuring Schematic Capture, Netlist, Boolean Equation and State Machine design entry methods.

CONNECTION DIAGRAM

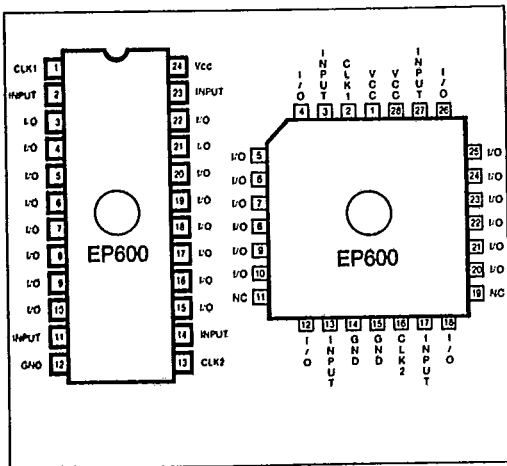

GENERAL DESCRIPTION

The Altera EP600 is a pin-compatible version of the popular EP610 Erasable Programmable Logic Device (EPLD). Available in 24-pin DIP and 28-pin J-leaded chip carrier packages, the EP600 contains 16 Macrocells with user-configurable I/O architecture, allowing up to 20 inputs and 16 outputs.

Each of the 16 Macrocells contains a programmable AND and fixed OR PLA structure, see Figure 1, with a maximum eight product terms for logic implementation. In addition, single product terms control Output Enable/Asynchronous Clock and Asynchronous Clear functions.

The Altera proprietary programmable I/O architecture allows the EP600 user to program output and feedback paths for both combinatorial or registered operation, active high or active low.

For increased flexibility, the EP600 also includes programmable registers. Each of the 16 internal registers may be programmed to be D, T, SR or JK flipflop. In addition, each register may be clocked asynchronously on an individual basis or synchronously on a banked register basis.

For proper operation, standard high performance design practices should be followed. It is recommended that opaque labels be placed over device window. Input and output pins must be constrained to the range $GND \leq (V_{IN} \text{ or } V_{OUT}) \leq V_{CC}$. Unused inputs must always be tied to an appropriate logic level (e.g. either V_{CC} or GND). Each set of V_{CC} and GND pins must be shorted together directly at the device. Power supply decoupling capacitors of at least .1µF must be connected between each V_{CC} pin and GND. For the most effective decoupling, connect one capacitor between each set of V_{CC} and GND pins, directly at the device.

Programming the EP600 is accomplished by using the Altera A+PLUS PC-based development software which supports schematic capture, netlist, state machine and Boolean equation design entry methods. Once the design is entered, A+PLUS automatically performs translation into logical equations, Boolean minimization, and design fitting directly to an EP600. The device may then be programmed to achieve customized working silicon within minutes at the designer's own desktop.

For full EP600 functional description please consult the EP610 datasheet.

REV 5.0

ALTERA

T-46-13-47

EP600

Figure 1 Logic Array Macrocell

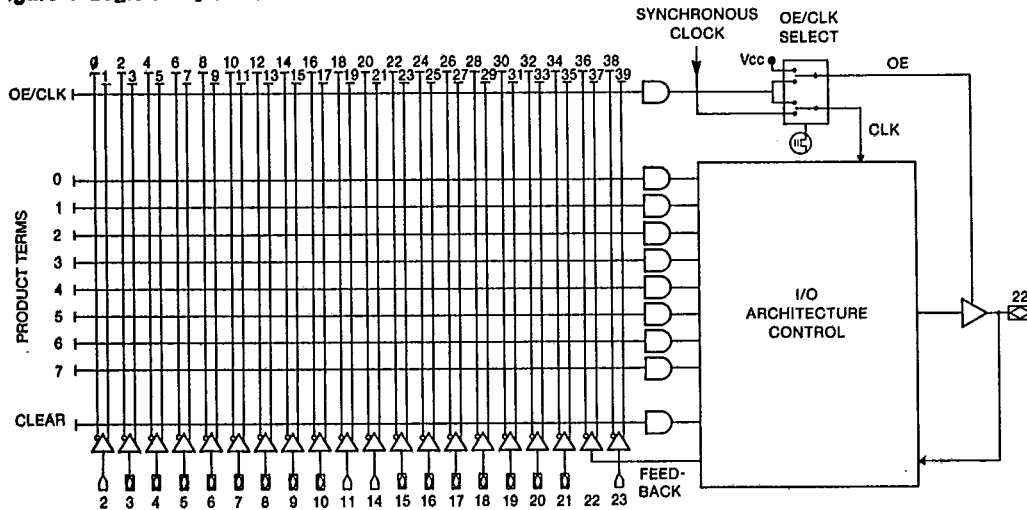

Note: = I/O pin, in which Logic Array input is from feedback path.

Figure 2. I_{CC} vs Frequency

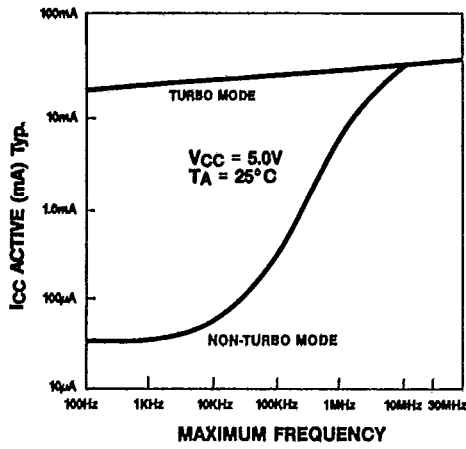
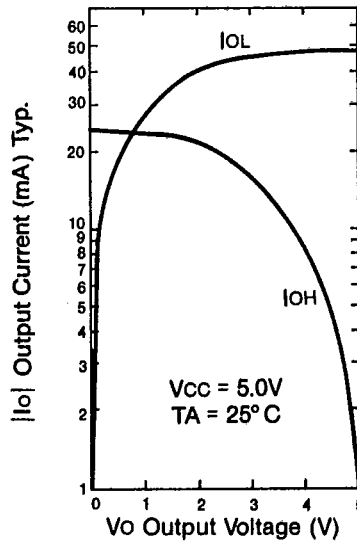

Figure 3. Output Drive Currents



2

EP600

ABSOLUTE MAXIMUM RATINGS

COMMERCIAL, INDUSTRIAL, MILITARY
OPERATING RANGE

T-46-13-47

Note: See Design Recommendations

SYMBOL	PARAMETER	CONDITIONS	MIN	MAX	UNIT
V _{CC}	Supply voltage	With respect to GND note (3)	-2.0	7.0	V
V _{PP}	Programming supply voltage		-2.0	13.5	V
V _I	DC INPUT voltage		-2.0	7.0	V
I _{MAX}	DC V _{CC} or GND current		-100	+100	mA
I _{OUT}	DC OUTPUT current, per pin		-25	+25	mA
P _D	Power dissipation			500	mW
T _{STG}	Storage temperature	No bias	-65	+150	°C
T _{AMB}	Ambient temperature	Under bias	-65	+135	°C

RECOMMENDED OPERATING CONDITIONS

SYMBOL	PARAMETER	CONDITIONS	MIN	MAX	UNIT
V _{CC}	Supply voltage	note (6)	4.75 (4.5)	5.25 (5.5)	V
V _I	INPUT voltage		0	V _{CC}	V
V _O	OUTPUT voltage		0	V _{CC}	V
T _A	Operating temperature	For Commercial	0	70	°C
T _A	Operating temperature	For Industrial	-40	85	°C
T _C	Case temperature	For Military	-55	125	°C
T _R	INPUT rise time	note (9)		500	ns
T _F	INPUT fall time	note (9)		500	ns

DC OPERATING CHARACTERISTICS

(V_{CC} = 5V ±5%, T_A = 0°C to 70°C for Commercial)
 (V_{CC} = 5V ± 10%, T_A = -40°C to 85°C for Industrial)
 (V_{CC} = 5V ±10%, T_C = -55°C to 125°C for Military)*
 Note (1) and (6)

SYMBOL	PARAMETER	CONDITIONS	MIN	TYP	MAX	UNIT
V _{IH}	HIGH level input voltage		2.0		V _{CC} + 0.3	V
V _{IL}	LOW level input voltage		-0.3		0.8	V
V _{OH}	HIGH level TTL output voltage	I _{OH} = -4mA DC	2.4			V
V _{OH}	HIGH level CMOS output voltage	I _{OH} = -2mA DC	3.84			V
V _{OL}	LOW level output voltage	I _{OL} = 4mA DC			0.45	V
I _I	Input leakage current	V _I = V _{CC} or GND	-10		+10	μA
I _{OZ}	3-state output off-state current	V _O = V _{CC} or GND	-10		+10	μA
I _{CC1}	V _{CC} supply current (standby)	V _I = V _{CC} or GND No load note (8)		35	150	μA
I _{CC2}	V _{CC} supply current (non-turbo)	V _I = V _{CC} or GND No load, f = 1.0 MHz note (7)		3	10 (15)	mA
I _{CC3}	V _{CC} supply current (turbo)	V _I = V _{CC} or GND No load, f = 1.0 MHz note (7)		30	50 (60)	mA

CAPACITANCE

Note (4)

SYMBOL	PARAMETER	CONDITIONS	MIN	MAX	UNIT
C _{IN}	Input Capacitance	V _{IN} = 0V f = 1.0 MHz		20	pF
C _{OUT}	Output Capacitance	V _{OUT} = 0V f = 1.0 MHz		20	pF
C _{CLK}	Clock Pin Capacitance	V _{IN} = 0V f = 1.0 MHz		20	pF

AC CHARACTERISTICS

EP600, EP600-3

T-46-13-47

(V_{CC} = 5V ± 5%, T_A = 0°C to 70°C for Commercial)
 (V_{CC} = 5V ± 10%, T_A = -40°C to 85°C for Industrial)
 (V_{CC} = 5V ± 10%, T_C = -55°C to 125°C for Military)*

SYMBOL	PARAMETER	CONDITIONS	EP600-3		EP600		NON-TURBO ADDER	UNIT
			MIN	MAX	MIN	MAX	note (5)	
t _{PD1}	Input to non-registered output	C ₁ = 50pF		43		53	25	ns
t _{PD2}	I/O Input to non-registered output			45		55	25	ns
t _{PZX}	Input or I/O Input to output enable			45		55	25	ns
t _{PXZ}	Input or I/O Input to output disable	C ₁ = 50pF note (2)		45		55	25	ns
t _{CLR}	Asynchronous output clear time	C ₁ = 50pF		45		55	25	ns
t ₀	I/O input buffer delay			2		2	0	ns

SYNCHRONOUS CLOCK MODE

SYMBOL	PARAMETER	CONDITIONS	EP600-3		EP600		NON-TURBO ADDER	UNIT
			MIN	MAX	MIN	MAX	note (5)	
f _{MAX}	Maximum frequency		26.3		23.3		0	MHz
t _{SU}	Input or I/O input setup time		38		43		25	ns
t _H	Input or I/O input hold time		0		0		0	ns
t _{CH}	Clock high time		17.5		21.5		0	ns
t _{CL}	Clock low time		17.5		21.5		0	ns
t _{CO1}	Clock to output delay			22		25	0	ns
t _{CNT}	Minimum clock period (register output feedback to register input - Internal path)			45		55	0	ns
f _{CNT}	Internal maximum frequency (1/t _{CNT})	note (7)	22.2		18.2		0	MHz

ASYNCHRONOUS CLOCK MODE

SYMBOL	PARAMETER	CONDITIONS	EP600-3		EP600		NON-TURBO ADDER	UNIT
			MIN	MAX	MIN	MAX	note (5)	
f _{MAX}	Maximum frequency		26.3		23.3		0	MHz
t _{ASU}	Input or I/O input setup time		10		10		25	ns
t _{AH}	Input or I/O input hold time		15		15		0	ns
t _{ACH}	Clock high time		17.5		21.5		0	ns
t _{ACL}	Clock low time		17.5		21.5		0	ns
t _{ACO1}	Clock to output delay			50		58	25	ns
t _{ACNT}	Minimum clock period (register output feedback to register input - Internal path)			45		55	0	ns
f _{ACNT}	Internal maximum frequency (1/t _{ACNT})	note (7)	22.2		18.2		0	MHz

Notes:

1. Typical values are for T_A = 25°C, V_{CC} = 5V
2. Sample tested only for an output change of 500mV.
3. Minimum DC input is -0.3V. During transitions, the inputs may undershoot to -2.0V for periods less than 20ns.
4. Capacitance measured at 25°C. Sample tested only. Clock pin capacitance for dedicated clock inputs only. Pin 13, (high voltage pin during programming), has capacitance of 50 pF max.
5. See TURBO-BIT™, page 44.
6. Figures in () pertain to military and industrial temperature version.
7. Measured with device programmed as a 16 bit counter.
8. EPLD automatically goes into standby mode if logic transitions do not occur when in non-turbo mode (approximately 100 ns after last transition).
9. Clock t_R, t_F = 250ns (100ns).
10. The f_{MAX} values shown represent the highest frequency for pipelined data.

GRADE	AVAILABILITY	
Commercial (0°C to 70°C)	EP600-3	EP600
Industrial (-40°C to 85°C)	EP600-3	EP600
Military (-55°C to 125°C)		EP600

* The specifications noted above apply to military operating range devices. MIL-STD-883 compliant product specifications are provided in military product drawings available on request from Altera marketing at 408/984-2805, ext. 101. These military product drawings should be used for the preparation of source control drawings.

2